

# BEFORE FITTING ALUMINUM WHEELS, PLEASE BE AWARE OF THE FOLLOWING

## CONFIRM THE CONTENTS OF THE PACKAGE

---

Before mounting tires, please first examine the products to ensure they match the vehicle. Also make sure that the product size, color, and P.C.D. are correct before the air valves, tires and balancing weights are fitted.

If there is any clear damage or missing items, please contact us immediately.

Please be aware that we cannot accept any returns on products which have been scratched and/or damaged after attempt of wheel installation.

## ADDITIONAL MARKS

---

The instruction contain the following important warnings:



**DANGER:** Highly likely to cause death or serious injury if instructions are not followed properly.



**WARNING:** Can result in death or serious injury if instructions are not followed properly.



**CAUTION:** Can result in personal injury or property damage if instructions are not followed properly.

These aluminum wheels comply with the technical standards that apply to light-alloy disk wheels for motor-vehicle use.

However, in the event vehicles are driven in non-conventional ways; or if vehicles are abused through racing, rallies and other activities that go beyond the wheel's limits of use; or if accidents or wheel deformities are caused by factors that are determined during regular maintenance checks or by cracks. exempts its liability for legal suits claiming compensation and takes no responsibility.

The warranties do not apply.

# BEFORE FITTING

## ! CHECKING THE WHEELS

THE NAME OF EACH WHEEL PART

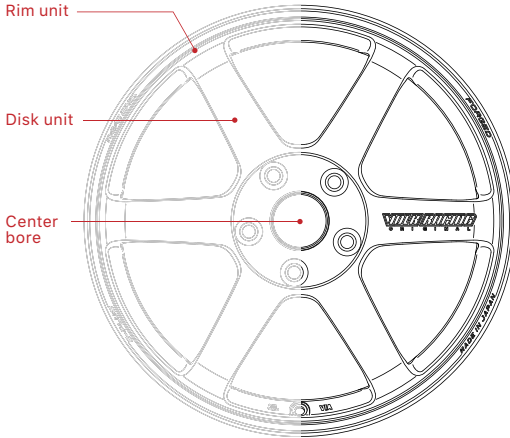

Please verify that the wheel size, number of holes, P.C.D., inset, configuration of mounting sides and nuts are compatible with the vehicle. Then fit the wheels to the hub, after fitment and compatibility have been confirmed.

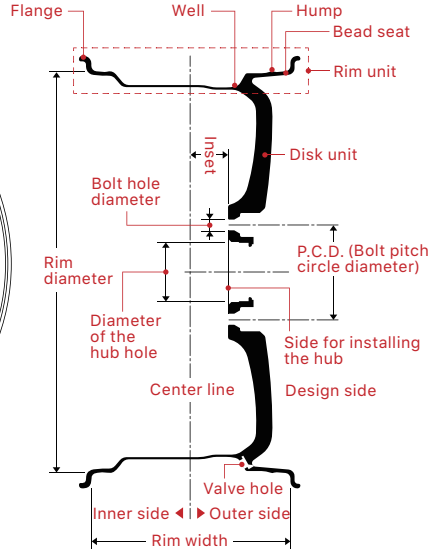

## ! APPROPRIATE TIRE SIZE SELECTION

When mounting the tire on a wheel, select a tire size that is compatible with the rim size. If a tire is mounted on a rim that is extremely wide in relation to the tire width (also known as "stretched tire"), it is extremely dangerous because the bead may fall off while driving or the rim flange may protrude, causing the rim to directly contact with the curb or other objects.

## ! VERIFYING THE BOLTS AND NUTS

Please confirm that your lug bolt/nut is compatible with the wheel. Attributes such as the thread pitch, seat type and thread length must be confirmed to ensure safety. If you use an improper size or shape of a lug bolt/nut, the bolt/nut may loosen from driving a vehicle.

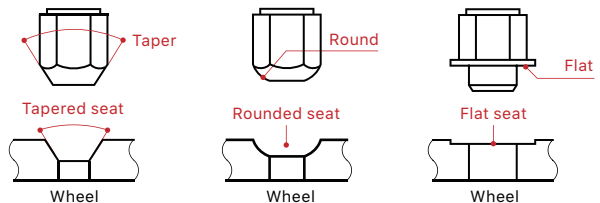

## BEFORE FITTING



### USING HUB RINGS AND OTHER PARTS

If the wheels use accessory spacers or hub rings, please make sure they are properly attached. Failure to do so can result in nuts and bolts working loose and coming off while the vehicle is traveling. Please ensure that hub rings are removed before replacing spare tires or the original wheels.



### ATTACHING THE AIR VALVES

Always use new accessory air valves. If the valves are not properly inserted in the valve holes, air leaks may occur. Also, please do not reuse valves once they have been removed and the grommets are used, as such valves can be the cause of air leaks.



### MOUNTING TIRES

When inflating tires during assembly, please take safety measures such as placing the tires inside a safety enclosure to reduce the risk of tire rupture. Special training is required by law to perform this inflating operation, so someone who has undergone such training must perform the work.



### VERIFYING AIR LEAKS

After the tires are assembled, please confirm there are no air leaks. Pay particular attention where the tire fits onto the rim and the area around the valve. Air leaks that occur while the vehicle is traveling can be extremely dangerous, as they can cause damage to the wheels and tires, leading to accidents.



### ADJUSTING BALANCE

After the tires are assembled, please adjust the balance of all the wheels. Improper balance can cause vibration and instability during driving, which can lead to friction on the tires. It is also advisable to have the tires aligned.

Also, if the suspension is installed with an extreme camber, etc., that causes an extreme load to be concentrated on the inner rim, the wheel may be subject to unbalanced stress, which may lead to damage or an accident; this is extremely dangerous. If possible, we also recommend vehicle alignment after installation.



### INSTALLATION BY VEHICLE TYPE

Depending on the vehicle model, there may be weights, assembly bolts, or locating pins protruding from the brake drum or mounting surface, or washers sticking out at the base of the bolts. Please ensure that these items do not encounter any part of the wheel.

## BEFORE FITTING

### ! TIGHTENING THE NUTS AND BOLTS

#### ● PLEASE USE A TORQUE WRENCH

Tighten nuts and bolts to the recommended torque. If your vehicle's instruction manual specifies a tightening torque for nuts (bolts), properly tighten them according to said manual.

- M10 at 50-70 N/m (5.1-7.2kgf/m)
- M12 at 85-132 N/m (8.7-13.5kgf/m)
- M14 at 125-180 N/m (12.8-18.4 kgf/m)

Over-tightening the nuts and bolts can alter the shape of their seats or damage the bolts. Conversely, failure to tighten them enough may cause them to loosen and come off. If an impact wrench is used, first tighten to a low torque and then use a torque wrench to tighten the lug nut to the recommended torque spec.

#### ● ORDER TO TIGHTEN BOLT/NUT

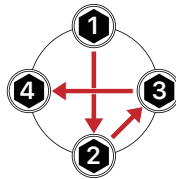

4 HOLE

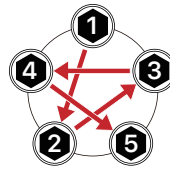

5 HOLE

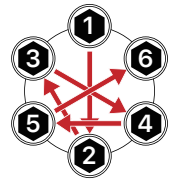

6 HOLE

## AFTER THE WHEELS ARE FITTED

### ! VERIFYING AFTER THE WHEELS ARE FITTED

After the wheels have been fitted onto the vehicle, check that they don't come into contact with any part of the body or the suspension system. (When checking the front wheels, turn the steering wheel all the way left and right.)

It is illegal for the wheels to protrude beyond the vehicle's outer fender.

### ! VERIFYING AIR PRESSURE

Before driving, always check the air pressure in the tires. For low profile tires in particular, low pressure reduces their ability to absorb impact and induces added stress on tires and wheels. Please make sure to check that the rubber seal ring inside the valve cap is attached and not loose.

Turn the valve cap approximately 90 degrees after the fastening point; tightening the valve cap too much may result in air leaks.

## AFTER THE WHEELS ARE FITTED

### **CONTINUING TO KEEP NUTS AND BOLTS TIGHT**

The nuts and bolts can easily become loose during the first 100 kilometers after the wheels are fitted or rotated. Use a torque wrench to make sure the nuts and bolts remain tight at the recommended torque.

### **PRECAUTIONS DURING DRIVING**

Never drive violently or wildly, such as sudden accelerating, braking and turning, as this not only puts added stress on the tires and wheels but also can cause accidents. Furthermore, driving over bumps or curbs and sidewalks can cause parts to bend and become misshapen. Driving while a wheel is bent out of shape can cause its wheel parts to crack.

## IF SOMETHING GOES WRONG

### **DEALING WITH PROBLEMS WHEN THINGS GO WRONG**

If you feel unusual vibrations or hear strange sounds while driving, immediately stop the vehicle in a safe place and check if the wheels' nuts and bolts and the shape of tires are okay. Should you find anything wrong with the wheels (deformities, cracks, loose nuts and bolts, air leaks, etc.), stop driving and immediately contact your dealer.

## REGULAR INSPECTIONS

### **REGULAR INSPECTIONS**

The aluminum alloy gives superior resistance to corrosion. Even so, always keep the wheels clean by washing them with plenty of water after driving in bad road conditions, where chemicals are used to prevent ice on the roads, or at seaside or snow areas, where salt is often present. If mud and salt are left on the wheels, their surfaces may become splotchy or discolored. When buying wheel or vehicle body cleaners, please read the products' instruction carefully as the products contain substances that can cause discoloration or splotches, such as abrasives and substances with high levels of acidity and alkaline. In addition, cleaning with highly concentrated alcohol disinfectants, thinners, and similar cleaners may damage the surfaces of the wheels, center caps, and other parts.

# PROHIBITED MODIFICATIONS

## ❌ PROHIBITED MODIFICATION S

We ask our customers and businesses never to modify our wheels. Modifications that involve welding or bending the wheels are extremely dangerous because they can reduce the wheel's strength or cause air leaks that can lead to broken parts or accidents. Furthermore, the bolts that attach the assembled wheels to the rims and disks are tightened at designated torque levels, so never disassemble, tighten or loose them.

**We will not acknowledge any claims concerning wheels that have been modified by the user.**

# INSTALLING THE CENTER CAP

## ! INSTRUCTIONS

For handling the center caps, please read and follow the instructions below. Please check that the wheel and center cap portion is cleaned and free from dust dirt.

- **DIAGRAM 1:** The center caps' O-rings (rubber rings) are covered in grease. Please do not remove it. If the amount of grease on the caps is insufficient when you reattach them after they have been removed, please re-apply new grease or lubricate the wheel assemblies.
- **DIAGRAM 1 and 2:** Insert the center cap at an angle and press the arrow marker. If pressed onto the design center part of the cap, it may damage/change shape.
- **DIAGRAM 3:** Install center caps with the included screws.
- **DIAGRAM 4:** Install center caps from the inside of wheel.

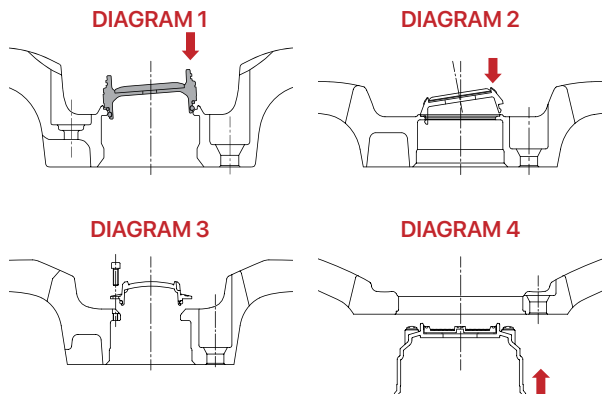

# REMOVING THE CENTER CAP

## ! INSTRUCTIONS



The center cap viewed from behind

- ① Turn the wheel with face on the bottom; upside down. As shown in the diagram below, press the arrow mark on the backside of the center cap and remove.
- ② There is a hole in the center of the backside of the center cap. **By no means should you press on the hole, as doing so can cause damage to the center cap or fade it's design.**
- ③ To avoid damaging the surface of the wheel when it is lowered, **rest it on a flat surface free from debris.**
- ④ Always ensure the cap is removed. **If it is damaged from an impact, such as being hammered, it may no longer fit and may come loose.**

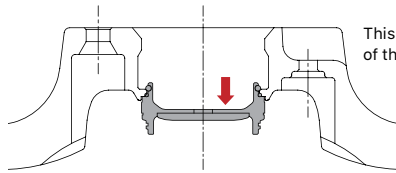

This diagram shows an example of the O-RING TYPE

## PRECAUTIONS FOR HANDLING ALUMINUM WHEELS

- As the surfaces of products incorporating special finishing or paint (including diamond mirror cut, sputtering, almite) are extremely delicate, long-term use of some wheel cleaners and other products can scratch and discolor the paint or corrode the aluminum. Please do not use cleaners that have too much acidity or alkalinity and by thoroughly using a soft cloth with as much water as possible.
- Do not use cleaners for planting or removing iron filings. If cleaning products are used, please carefully read the instructions to ensure that there is no damage to the finish. Scratches to the wheel surface caused when cleaning or rubbing the side of curbs cannot be repaired.
- Friction from sponges or partial compounds can cause scratches.
- Avoid using high-speed car washing machines for cleaning wheels.
- When tires and wheels are removed for storage, please thoroughly wash and dry them. Do not store them in places of direct sunlight, high temperature, or humidity.